

BenQ IT1001 Mobile Cart Assembly Instructions



Compatibility: Up to Vesa 800x600mm and displays from 55 to 86 inches.

Weight capacity: 100Kg/220.5Lbs

Required tools: Phillips #3 screwdriver

| Packing List | | |
|--------------|---|----------------|
| | Description | Quantity |
| 1 | Base | 1 |
| 2 | 2.5 Inch universal casters with brake | 2 |
| 3 | 2.5 Inch universal casters | 2 |
| 4 | Left vertical column | 1 |
| 5 | Right Vertical column | 1 |
| 6 | Shelf | 1 |
| 7 | Phillips/Hex Bolt M6x16mm | 16 |
| 8 | M14 Split lock washer/M14 Flat washer/M14 Nut | 4 of each item |
| 9 | M6x16mm Phillips head screw | 4 |
| 10 | Horizontal VESA mounting plate | 1 |
| 11 | Universal vertical VESA mounts | 2 |
| 12 | M5x100mm Phillips head screws | 2 |
| 13 | M8x70mm Hex Bolt | 4 |
| 14 | M8 Split lock washer/M8 washer/M8 nut | 4 of each item |
| 15 | Assembly tool | 1 |

Mobile cart assembly instructions:

Step 1: Remove the base and install the 2 universal casters with brakes (2) using the included M6 screws (7.) ***Important*** The casters with brakes must be installed to the front edge of the base, the front can be found by identifying the edge that is furthest from the cross member (148mm.) You can now install the casters without breaks on the side of the base that is 98mm from the cross member.

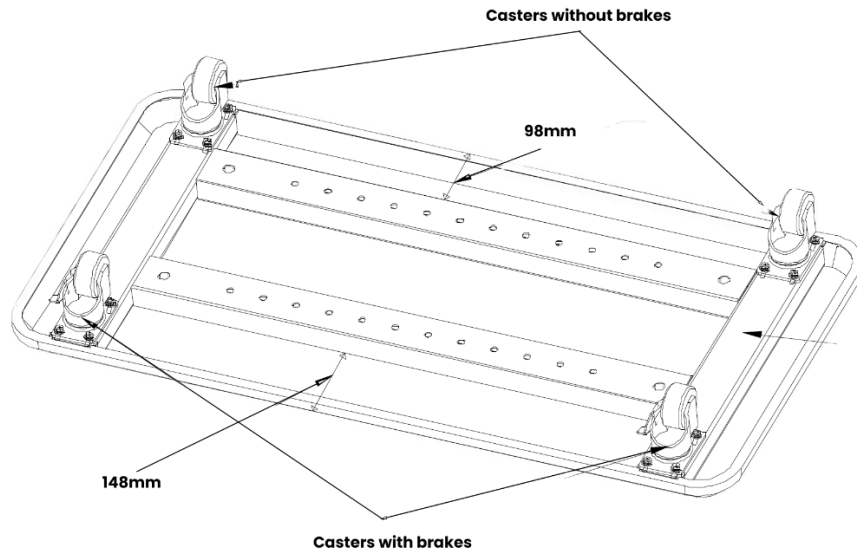

Step 2: Insert the left and right vertical columns into the base. ***Important*** the threads for mounting the shelf must face towards the inside of the cart. Fix the left and right vertical columns to the base using the included M14 Split lock washer/M14 Flat washer/M14 Nut. The correct order goes as follows flat washer>split spring washer>nut. Snug up the nut with the wrench but do not tighten. You can tighten up the nut once the shelf is installed.

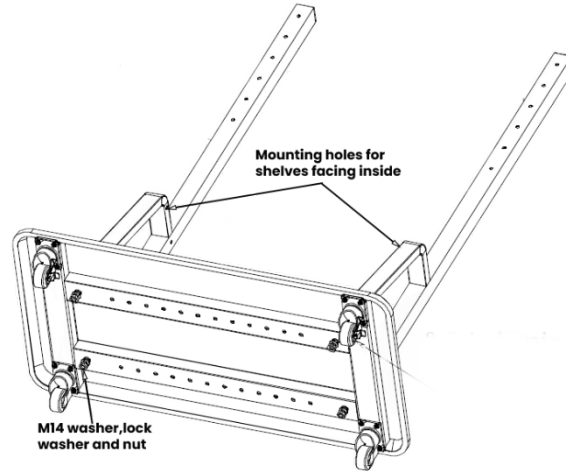

Step 3: With the vertical columns in place, remove the screw from the mounting holes for the shelf. Slide the shelf into position and fix it in place with the screws. You can now tighten the nuts for the columns installed in the last step.

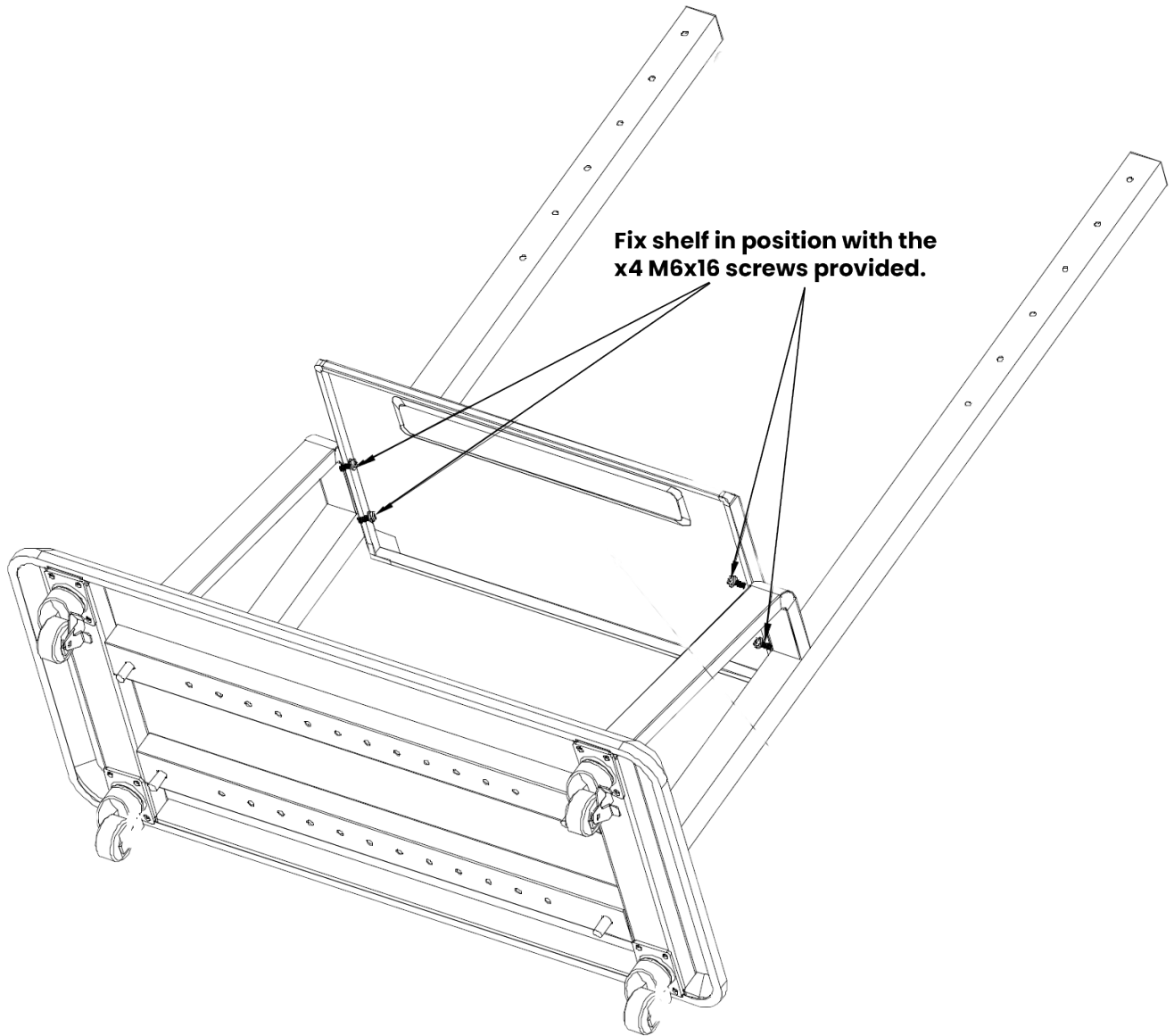

Step 4: Fix the vertical VESA mounting adapter to your display. Please remove the mounts that come preinstalled on the display and replace with the mounts from the IE1001 mobile cart kit.

Step 5: Determine the height for the display. Install the horizontal VESA mounting plate to achieve the desired height. Use the M8x70mm hex bolts and insert them from the front then use the M8 washer, M8 Split lock washer, M8 nut in that order to fix the mounting plate in place.

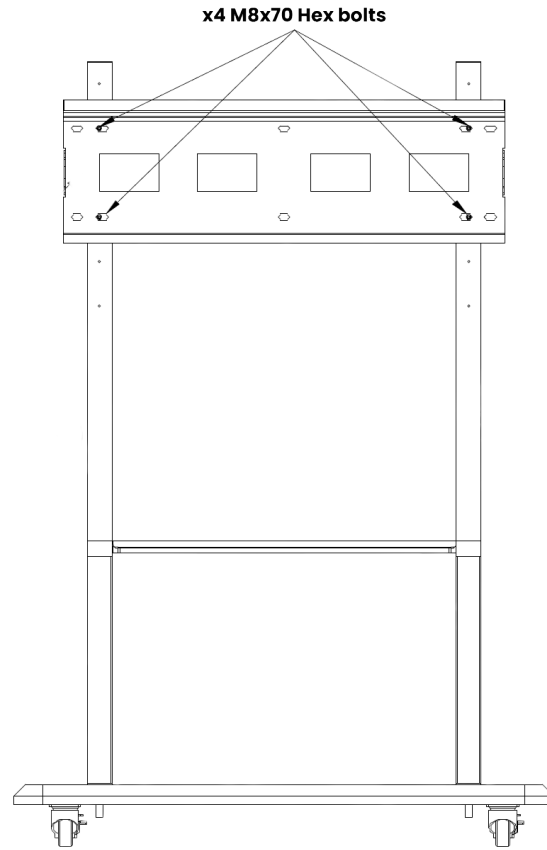

Step 6: Hang the display on the mobile cart. Use the x2 preinstalled M5x100mm security screws to lock the display to the mobile cart.

